

High Resolution Day & Night Box Camera

TANDÉR® BX-DN550EX-K



Key Features

- 1/3" SONY Ex-View CCD
- High Resolution 550 TV Lines
- Stylish Aluminium Casing
- 0.002 Low Lux (SENS-UP)
- Made in Korea

Specifications

Brand	TANDER
Model	BX-DN550EX-K
Image Pick-up Devise	1/3" SONY Ex-View CCD
Signal System	PAL
Total Pixels	795(H)x 596(V) / 470K
Scanning System	2 : 1 Interlace
Lens	No Iris / Auo Iris (DC/Video) (C / CS Mount)
Frequency	15.62KHz (H), 50.00Hz (V) - PAL
Resolution	550 TV lines
Video Output	CVBS : 1.0Vp-p / 75Ω
S / N Ratio	50dB (AGC On)
Sync. System	Internal
Min. Illumination	0.3 Lux (Color) / 0.1 Lux (B/w) 0.002 Lux (SENS-UP)
Signal Process	Digital Signal Processing
Shutter Speed	AUTO / MANUAL
Gain Control	OFF / LOW / MIDDLE / HIGH
Electronic Shutter Speed	Auto / (1/50 ~ 1/100,000)
White Balance	ATW / AWC / MANUAL
Iris Control	DC
Power Source	12V DC ±10%
Power Consumption	Max. 1.8W
Operating Temperature	-10°C ~ +50°C
Operating Humidity	30% ~ 90% RH
Dimension	65(W) x 59(H) x 109(D) mm
Weight	325g
Country Of Origin	Korea

Dimensions

(Unit: mm)

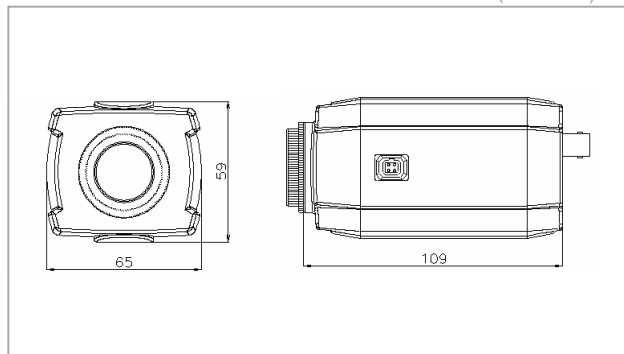

Connection Diagram

